

Coyote Stainless Steel Combo Gas Grill Use & Care Manual

For Liquid Propane and Natural Gas Models

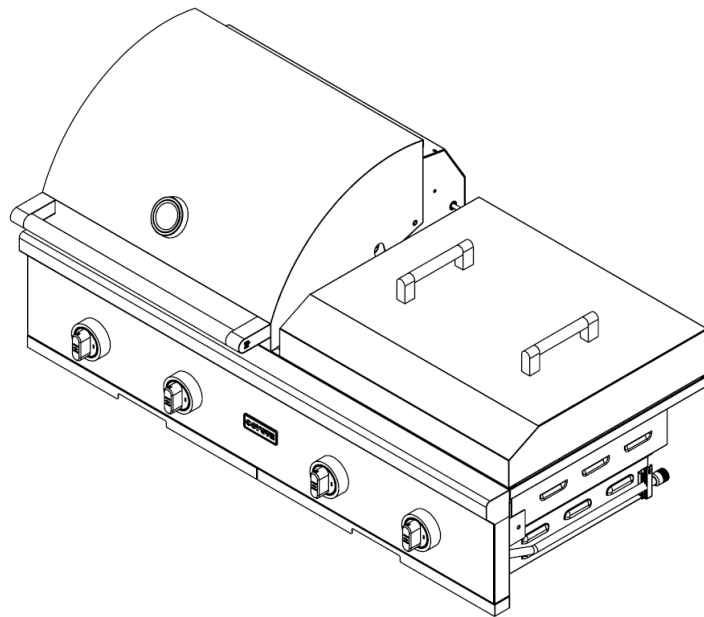

C3CO50LP
C3CO50NG

PUT SERIES NO. LABEL HERE

FOR OUTDOOR USE ONLY

Conforms to ANSI STD Z21.58
Certified to CSA STD 1.6 Outdoor Cooking Gas Appliances
CSA/ANSI Z21.58:22-CSA1.6:22 Outdoor Cooking Gas Appliances



IMPORTANT: Read all instructions and warnings carefully before using this product.

Like any outdoor grill, using this product involves potential risks from high temperatures and exposure to smoke and fumes. Please exercise caution and common sense to ensure safe operation.

- **For the Installer or Assembler:** Leave this manual with the grill for the consumer's future reference.
- **For the Consumer:** Retain this manual for future reference as it contains essential warnings and instructions.



Welcome & Congratulations!

Congratulations on purchasing a **Coyote Outdoor Living Gas Grill**. You have chosen a high-quality, innovative, and stylish product from a company dedicated to enhancing your outdoor cooking experience. We are thrilled to welcome you to the **Coyote family!**

Get Started

- **Register Your Grill:** Please register your grill at www.CoyoteOutdoor.com. Registration ensures you receive updates and personalized support for your grill.
- **Need Assistance:** If you have any questions, please call our Customer Support Team at **855-520-1559**. We are here to help.

Read, Save, and Follow the Instructions

For optimal performance and longevity of your grill:

- Carefully **read this manual** to understand how to install, operate, and maintain your grill.
- Always **obey all warnings and instructions** outlined in this manual.

This manual provides specific operating instructions for your gas grill model. While it covers most scenarios, it is essential to apply common sense and exercise caution when installing, using, or maintaining your appliance.

Need a Replacement Manual?

1. **Download a replacement** at www.CoyoteOutdoor.com
2. **Contact Customer Support** at **855-520-1559** for assistance.

Thank you for choosing **Coyote Outdoor Living**. We are confident you will enjoy cooking with your new gas grill for years!

Welcome to the Coyote family!

Grill Safety and Lighting Instruction Videos



Register your Grill



Contents

Important Warnings and Safety Instructions..... 3

Limited Warranty 5

Locating the Grill 7



Gas Requirements..... 10

Operating the Grill 15



Care and Maintenance..... 18

Troubleshooting your Grill 20



Safety Symbols

 **DANGER** 



DANGER indicates an imminently hazardous situation which, if not avoided, will result in death or serious injury.

 **CAUTION** 



CAUTION indicates a potentially hazardous situation which, if not avoided, may result in minor or moderate personal injury, or property damage.

 **WARNING** 

WARNING indicates a potentially hazardous situation which, if not avoided, could result in death or serious injury.



 **WARNING** 

FOR OUTDOOR USE ONLY:
 NEVER operate grill in enclosed areas, as this could lead to gas accumulating from a leak, causing an explosion or a carbon monoxide buildup which could result in injury or death. DO NOT use your grill in garages, breezeways, sheds, or any enclosed area. NOT FOR USE BY CHILDREN. If these instructions are ignored, a hazardous fire or explosion could result in physical injury, death, or property damage!

 **DANGER** 

IF YOU SMELL GAS:

1. Shut off gas to the appliance.
2. Extinguish any open flame.
3. Open Lid.
4. If odor continues, keep away from the appliance, and immediately call your gas supplier or your fire department.

 **WARNING** 

WARNING:

1. DO NOT store or use gasoline or other flammable liquids or vapors in the vicinity of this or any other appliance.
2. A Liquid Propane (LP) cylinder not connected for use shall not be stored in the vicinity of this or any other appliance.

Important Warnings and Safety Instructions



WARNING



Improper installation, adjustment, alteration, service, maintenance or use can cause injury or property damage. Read the installation, operating and maintenance instructions thoroughly before installation or servicing of this equipment.



WARNING



General Safety Instructions for Coyote Grills

Intended Use

- Coyote grills are designed exclusively for **outdoor use** and must not be used indoors or in enclosed spaces such as garages, sheds, or breezeways.
- These grills are intended for **residential use** by the original purchaser (homeowner) and are unsuitable for commercial applications.
- Do not install the grill on recreational vehicles, portable trailers, boats, or any other moving installation.

Fire and Explosion Prevention

- **Ventilation and Combustion:** Use the grill only in open areas with **good ventilation** to prevent toxic fume buildup, fire, or explosion. Never obstruct airflow or ventilation.
- **Keep Area Clear:** Maintain a clean area around the grill, free from flammable liquids and materials such as cleaning fluids, gasoline, or lighter fluid.
- **Wind Conditions:** Avoid using the grill in windy conditions. Use a windbreak if it is located in a windy area (e.g., oceanfront or mountaintop). Adhere to clearance guidelines.
- **Gas Compatibility:** Never use natural gas in a grill designed for liquid propane or vice versa.
- **Drip Tray Usage:** Always grill with the drip tray properly in place to prevent grease fires or explosions.

Burn and Injury Prevention

- **Supervision:** Never leave the grill unattended while in use.
- **Child and Pet Safety:** Keep children and pets away from the grill, especially when it is hot.
- **Burn Hazards:**
 - Avoid leaning over an open grill, as heat and steam can cause burns.
 - Wear appropriate clothing (avoid loose or flammable fabrics) and use heat-resistant gloves when handling hot surfaces.
 - Open the grill hood slowly to allow heat and steam to escape.
- **Grease Fires:** Never attempt to extinguish a grease fire with water.
- Use an **ABC fire extinguisher** to put out flames.
- **Handling Grease:** Allow grease to cool before handling or disposing.
- Regularly clean the drip tray to prevent grease buildup.

Gas and Leak Safety

1. **Leak Testing:** Only use the grill once a **leak test** has been completed.
2. **Gas Connections:** Turn off the LP cylinder valve and control knobs when the grill is not in use.
3. Keep gas supply lines as short as possible and correctly connect them.
4. **Gas Cylinder Storage:** Never store a spare gas cylinder under or near the grill.
 1. Ensure gas cylinders are stored upright and away from heat sources or enclosed areas.
5. **Unregulated Gas Lines:** Never connect an unregulated gas line to the grill, as it can cause excessive heat, fire, or damage.

Operation and Maintenance

- **Use Only Approved Accessories.**
- Do not use lighter fluid or other accelerants in a gas grill.
- **Electrical Safety:** Keep electrical cords away from water and hot surfaces.
- Use only a Ground Fault Interrupter (GFI)-protected circuit for outdoor cooking appliances.
- **Moving the Grill:** Never move it while it is hot or in use.
- **Container Safety:** Never heat unopened glass or metal containers on the grill, as pressure buildup may cause the container to burst.
- **Regular Maintenance:** Inspect the grill regularly for grease buildup, leaks, or signs of wear.
- Only a qualified technician should perform repairs or replacements.

Emergency Procedures

- **Burner Outages:** If a burner goes out, turn all control knobs to the **OFF** position, fully open the hood, and let the grill air out before attempting to relight.
- **Fire Precautions:** Always have an **ABC fire extinguisher** nearby and accessible when using the grill.

Additional Guidelines

- **Alcohol and Drug Use:** Never operate the grill under the influence of drugs or alcohol.
- **Clearance Requirements:** Adhere to clearance guidelines specified in the user manual to ensure proper ventilation and safe operation.
- **Proper Shutoff:** Turn off the LP cylinder tank valve and ensure all control knobs are in the **OFF** position after use.

Key Reminders

- Keep the grill in a well-ventilated outdoor area, free of combustible materials.
- Never leave the grill unattended while cooking.
- Follow all maintenance and safety guidelines to ensure safe and optimal operation.



DO NOT RELY JUST ON THIS SAFETY SECTION. USE CAUTION AND COMMON SENSE AT ALL TIMES.
PLEASE READ THE REST OF THIS MANUAL CAREFULLY FOR OTHER IMPORTANT SAFETY WARNINGS.

CALIFORNIA PROPOSITION 65 - WARNING: This product can expose you to Carbon Monoxide, which is on the list of substances known by the state of California to cause cancer, birth defects, or reproductive harm. For more information, go to: www.p65warnings.ca.gov. California law requires businesses to warn customers of potential exposure to such substances. To minimize exposure to these substances, always operate this unit according to the Use and Care Manual, ensuring you provide good ventilation

Limited Warranty

Coyote Outdoor Living, Inc. Limited Warranty

General Terms

To the maximum extent permitted by law, this **Limited Warranty** and the remedies outlined herein are **exclusive** and supersede all other warranties, whether oral or written, express or implied. **Coyote Outdoor Living, Inc.** expressly disclaims any implied warranties, including but not limited to warranties of **merchantability** and **fitness for a particular purpose**.

This warranty is provided to the **original purchaser** at the original delivery site with proof of purchase and applies only to **residential use**. The warranty covers defects in workmanship and materials under regular residential use for the specified periods outlined below. It is **non-transferable** and does not apply to any grill used in a **commercial setting**. Surface corrosion, scratches, discoloration, and other cosmetic issues arising from regular use are explicitly excluded.

Warranty Coverage Periods

Lifetime (no rust or burn-through)

- **Cooking Grids**
- **Heat Control Grids**
- **Stainless Steel Frame/Housing**
- **Stainless Steel Burners**

One Year

- **Ignition Systems/Valves**
- **Electric/Plastic Components**

Coyote's Obligations

Coyote Outdoor Living, Inc. will repair or replace defective components at its discretion during the warranty period. Replacement or repair is the **exclusive remedy** under this warranty. Liability under this warranty is limited to the cost of the replacement part or repair. **Labor and labor-related charges are not covered**, and customers are responsible for shipping and handling fees for replacement parts.

Exclusions

This Limited Warranty does **not** cover:

Normal wear and tear or damage caused by:

- Misuse, negligent use, or abuse of the product.
- Improper fuel/gas supply.
- Failure to follow operating instructions.
- Alterations by anyone other than a factory-authorized technician.

Cosmetic issues, including but not limited to:

- Scratches, dents, corrosion, or discoloration due to weather, heat, abrasive cleaners, chemical exposure, or pool and spa chemicals.
- Paint loss, surface rust, or stainless-steel discoloration are considered **normal wear and tear**.
- **External factors include damage** from accidents, vandalism, flashback or grease fires, and improper installation, maintenance, or service.
- Severe weather events (hail, hurricanes, tornadoes, earthquakes, etc.), terrorism, Acts of God, or exposure to atmospheric chemicals.
- **Inconveniences or damages:** Personal injury, property damage, or any incidental or consequential damage arising from improper use or product failure.

Warranty Claim Procedure

If you require service or replacement parts for your Coyote Grill, follow these steps:

- **Contact the Warranty Service Center:** Phone: **855-520-1559**
- Email: support@coyoteoutdoor.com
- Website: www.coyoteoutdoor.com (Warranty claims can be submitted online.)
- **Provide Required Information:**
 - Model number.
 - Serial number.
 - Proof of purchase.

Coyote Outdoor may require defective parts to be returned for examination. Customers are responsible for prepaying shipping charges. If the part is deemed defective, Coyote Outdoor will approve the claim and issue replacement parts at no charge. Shipping and handling costs for replacement parts remain the customer's responsibility.

Important Notes

- **Exclusion of Extended Warranty:** Warranty periods are not extended by any repair or replacement.
- **Customer Responsibility:** The customer is responsible for the proper maintenance and operation of the grill, as outlined in the product manual.
- **Non-Covered Issues:** Damages from misuse, improper cleaning, and exposure to harsh environmental conditions are not covered.

Limitation of Liability

To the maximum extent permitted by law, Coyote Outdoor Living, Inc. shall not be liable for:

- Incidental or consequential damages.
- Costs of inconvenience, personal injury, or property damage resulting from improper use or product failure.

This Limited Warranty constitutes the sole and exclusive warranty provided by Coyote Outdoor Living, Inc.; no other warranties, express or implied, will apply.

Infinity Burner BTU Output

- Each Infinity Burner is designed to produce up to **20,000 BTUs** of heat output.
- The grill is **optimized for fuel efficiency** and **cooking performance** so that the actual BTU output may vary based on operating conditions and settings.

If you have questions about BTU output or performance, please call Coyote Customer Support at **855-520-1559** for detailed information.

Locating the Grill

Check your local building codes for the proper method of installation. In the absence of local codes, this unit should be installed in accordance with the *National Fuel Gas Code No. Z223.1-1998 USA* or *CAN/CGA-8149.1/.2 Natural Gas/Propane Code (Canada)* latest edition or the *National Electrical Code ANSI/NFPA No. 70* or the *Canadian Electrical Code CSA C22.1, 1990* or latest version.

Installation and Safety Guidelines for Coyote Grills



Pre-Installation Recommendations

- **Record Product Information:** Before installing a built-in grill, copy the product details, including the **model number**, **serial number**, and **fuel type** (e.g., natural gas or LP). Store this information in a safe place for future reference.
- **Locate Gas Shut-Off:** If the grill is installed by a professional, ensure they show you the location of the **gas supply shut-off valve**. The valve must be **readily and easily accessible**.
- **Check for Gas Leaks:** If you smell gas, check for leaks using a **soap and water solution**. Never inspect leaks with an open flame.

Notice: Professional installation of your Coyote Grill is highly recommended. These instructions provide the necessary measurements for constructing a masonry structure to house your outdoor gas grill.

Location Requirements

Outdoor Use Only: Always install the grill in a well-ventilated outdoor area. If placing the grill in an enclosed space such as a garage, shed, or breezeway, ensure it is equipped with a properly approved ventilation system.

Minimum Ambient Operating Temperature: 0°F (-17.8°C)

Definition of Outdoor Installation:

- An appliance is considered outdoors if installed with shelter no more inclusive than with walls on three sides but with no overhead cover; all openings must be permanently open; sliding doors, garage doors, windows, or screened openings are not considered permanent openings.
- An appliance is considered to be outdoors if installed with shelter no more inclusive than within a partial enclosure that includes an overhead cover and no more than two sidewalls. The sidewalls may be parallel, as in a breezeway, or at right angles to each other; all openings must be permanently open; sliding doors, garage doors, windows, or screened openings are not considered as permanent openings.
- An appliance is considered to be outdoors if installed with shelter no more inclusive than within a partial enclosure that includes an overhead cover and three sidewalls, as long as 30% or more of the horizontal periphery of the enclosure is permanently open. All openings must be permanently open; sliding doors, garage doors, windows, or screened openings are not considered as permanent openings.

Smoke Ventilation: Choose a location where smoke can disperse quickly to avoid inhalation of potentially harmful fumes.

Gas Supply Pressure Warnings:

- The outdoor cooking gas appliance and its individual shut-off valve must be disconnected from the gas supply piping system during any pressure testing of that system at test pressures in excess of 1/2 psi (3.5 kPa).
- The outdoor cooking gas appliance must be isolated from the gas supply piping system by closing its individual manual shut-off valve during any pressure testing of the gas supply piping system at test pressures equal to or less than 1/2 psi (3.5 kPa).

Ventilation Requirements

Proper ventilation allows heat and gas to escape, ensuring safe and efficient operation. Failure to meet ventilation requirements will void the Coyote warranty and pose a risk of injury or death.

1. **Ventilation for Built-in Islands:**
 - Islands must have **at least two vents** (optimally four) per cabinet containing gas connections.
 - Each vent must be **at least 20 sq. inches** in size and open to outside air.
 - **Propane grills:** Place vents at or below the height of the tank valve, as propane is heavier than air.
 - **Natural gas grills:** Place vents at or above the gas connection height, as natural gas is lighter than air.
2. **Wind Considerations:**
 - Select a location that accounts for typical wind conditions to prevent heat buildup inside the grill or island.
 - Wind can block exhaust and trap heat, causing control panels and knobs to overheat and potentially damage components like ignition systems or rubber gaskets.
3. **Optional Wind Guards:**
 - **Coyote Wind Guards** can help divert wind over the grill, reducing overheating risks. However, they are not guaranteed to solve ventilation issues in high-wind conditions. These can be purchased from authorized dealers.

Clearance Requirements

1. **From Non-Combustible Materials:**
 - If a **wall or partition** behind the grill blocks ventilation, we recommend maintaining a minimum clearance of **7 inches** from the back of the grill.
 - A **2-inch minimum clearance** behind the grill will allow the hood to open fully.
 - Allow **6 inches of clearance** on each grill side for the motor and spit handle to be used in a rotisserie.
2. **From Combustible Materials:**
 - Maintain at least **24 inches of clearance** from combustible materials below the countertop.
 - Maintain at least **15 inches of clearance** from combustible materials behind the grill above the countertop.
 - Never locate the grill under combustible structures unless an **approved ventilation hood** is installed:
 - The hood must be UL-certified, designed for outdoor Use, and installed per the manufacturer's specifications.
 - It should be installed at least **30 inches above** the cooking surface and be **6 inches wider than the grill frame** (3 inches on each side).
3. **Insulated Jackets:**
 - If the grill is within 24 inches of combustible materials below the countertop, an appropriate Coyote insulated jacket must be used. Failure to use an insulated jacket voids the warranty and compromises safety.

Built-in Installation

1. **Masonry Installation:**
 - A built-in grill can be installed into masonry enclosures without a bottom deck to support the grill. The weight of the grill body is supported by the countertop within the cutout opening.
 - Do not enclose the grill and block the ventilation around the grill's body.
 - Ensure the **countertop is flat and level** relative to the floor.
 - Install **two or more vents**, each at least **20 sq. inches** in size, for proper ventilation:
 - **Propane grills:** Position vents at or below tank valve height.
 - **Natural gas grills:** Position vents at or above the gas connection.
2. **LP Tank Storage:**

- Store LP tanks in a **separate, ventilated compartment** with **bottom vents** for proper airflow.

High-Elevation Use

- Coyote Grills are optimized for operation at **0-2000 feet** above sea level elevations.
- Performance remains stable between **2000-4000 feet**, though more gas combusts due to reduced oxygen levels.
- Cooking times above **4000 feet** may increase due to air/fuel mixture changes. For questions regarding high-elevation installation, contact **Coyote Customer Support** for guidance.

Key Safety Notes

- Proper ventilation is critical for safety and performance.
- Always adhere to clearance guidelines to prevent overheating and ensure warranty validity.
- Use Coyote-approved insulated jackets and ventilation hoods for combustible materials or high-risk areas.

Cutout Dimensions

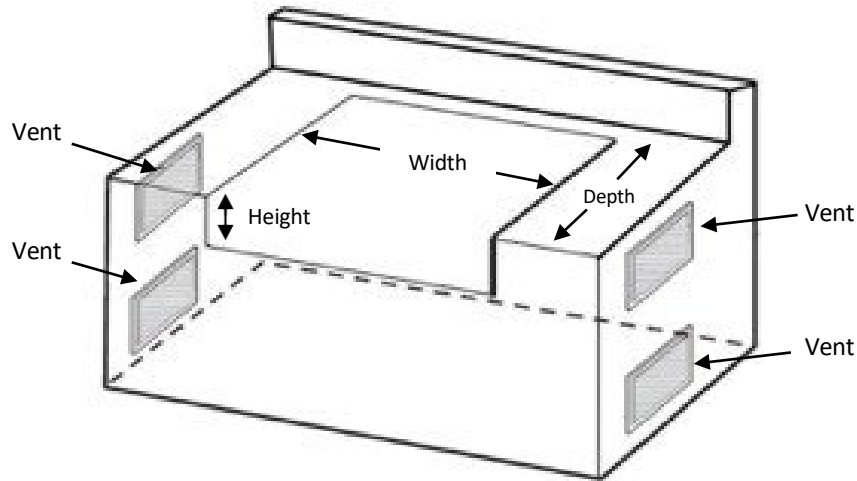

⚠ DANGER ⚠

Cabinets with any gas supply or connection are required to have a minimum of two vents, with four vents being the optimal configuration. Each vent must be at least 20 square inches in size and provide direct access to outside or fresh air. To ensure proper airflow and ventilation, it is recommended to place two vents on each side of the cabinet.

Model	Cutout Dimensions			Overall Dimensions			Total BTU Ratings		Other	
	Height	Width	Depth	Height	Width	Depth	LP	NG	Rotisserie	Lights
C3C050	10 1/4"	47 3/4"	20 1/2"	23"	50"	25 1/2"	60,000	60,000	No	No

Gas Requirements

Note: Coyote strongly recommends that a qualified service technician perform the initial installation and all conversions or modifications to the gas supply.



Never attach an unregulated gas line to the appliance. Connection to an unregulated gas line can cause excessive heat or fire and the risk of property damage, bodily injury, or death.

Critical Safety Warnings

1. **Do Not Use Unregulated Gas Lines:**
Never attach an unregulated gas line to the grill. This can result in excessive heat or fire, which can cause property damage, injury, or death.
2. **Control Knobs:**
Always ensure the grill control knobs are in the **OFF** position before connecting the grill to a gas source.

Gas Connection Instructions

1. **Verify Gas Type:** Confirm whether the grill is designed for **natural gas (NG)** or **liquid propane (LP)**. Do not connect an LP grill to a natural gas supply or vice versa.
 - Check the appliance rating label for compatibility with the gas supply.
2. **Gas Supply Regulations:** The installation must comply with **local codes** or, in their absence, adhere to the following:
 - **National Fuel Gas Code (ANSI Z223.1/NFPA 54)**
 - **Natural Gas and Propane Installation Code (CSA B149.1)**
 - **Propane Storage and Handling Code (CSA B149.2)**
 - Use approved pipe sealants resistant to LP gas, but **never use pipe sealants on flare fittings.**
3. **Pre-Operation Check:**
 - Gas valves are preset at the factory for natural gas or propane. Contact your dealer to convert your grill to a different gas type.
 - Always check the rating plate to confirm the gas supply matches the grill's manufacturing specifications.

Liquid Propane (LP) Gas Guidelines

- **Key Characteristics of Propane:**
 - Propane is flammable, explosive under pressure, heavier than air, and can pool in low areas.
 - Propane is odorless in its natural state; an odorant is added for safety.

Safety Precautions:

- Never use a propane cylinder that is damaged, dented, or rusted.
- Always store the LP cylinder upright, securely fastened, and away from excessive heat.
- Do not store LP cylinders indoors or near gas-burning appliances.
- **Cylinder Specifications:**
 - Use only cylinders 12 inches in diameter and 18 inches high, with a maximum capacity of 20 lbs. of propane (80% full).

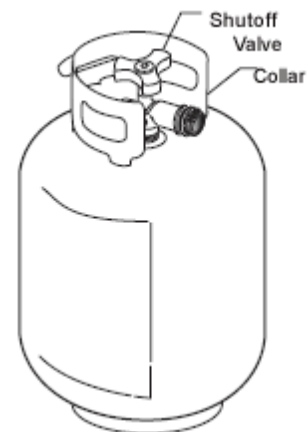

- (Except model C3SL42LP, use with a 30lbs of propane only.)
- Ensure cylinders comply with DOT or CSA B339 standards and include overfilling prevention devices.

LP (Propane) Gas Connection Process

1. Ensure the **tank valve** is in the **OFF** position.
2. Confirm all **burner control knobs** are in the **OFF** position.
3. Connect the **regulator** to the tank valve:
 - Insert the regulator inlet into the valve and turn the nut clockwise until tight.
 - Avoid over-tightening.
4. **Purge Air from the System:**
 - Turn the main tank valve on and the burner control valves to **HIGH** for 20 seconds to purge air before lighting.
5. Leak test all connections:
 - Use a soapy water solution to check for leaks. Tighten any connections if bubbles appear.
 - Do not use thread sealant on the brass LP flare fittings.



Key Features of the LP Hose and Regulator System

- It prevents gas flow until a positive connection is made.
- Includes a thermal element that shuts off gas during a fire.
- Features a flow-limiting device to restrict gas flow in case of a leak.

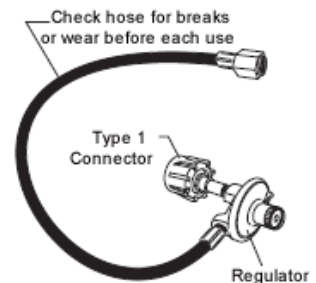

Propane Cylinder Handling and Storage

1. **Disconnection:**
 - Turn off all control knobs and the tank valve.
 - Detach the regulator by turning the coupling nut counterclockwise.
 - Install the safety cap onto the LP tank valve.
2. **Storage:**
 - Never store LP tanks in enclosed spaces or vehicles.
 - Keep tanks upright and away from areas where children play.
3. **Filling and Transporting:**
 - Use licensed LP dealers and ensure tanks are filled to no more than **80% capacity**.
 - Always assess new or exchanged tanks for leaks before connecting to the grill.

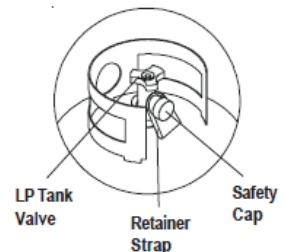

Important: Always leak-test the hose and regulator before using the grill.

Large-Capacity Propane Systems

If connecting to a large propane tank (e.g., a home's central propane system):

1. Use an **in-line LP regulator** purchased from an authorized dealer or plumbing supply company.
2. Ensure compliance with all state, county, and federal codes.

In-Line Convertible Regulator

Model # CINLNREG

Coyote sells a separate inline regulator for whole-home propane systems. This regulator can be used for Natural Gas (NG) or Propane (LP). It comes pre-set for Natural Gas, and you must convert it to Propane by performing the steps below.



	1. Left icon is NG setting
 <p>NUT</p> <p>REGULATING POLE</p>	2. Unscrew the regulating pole
 <p>180°</p>	3. Change the regulating pole to other side for LP
	4. Lock the regulating pole as left icon. a. It is necessary to close the lock 5. Lock the nut to regulator (necessary to close the lock)



Image of the regulating pole set to LP.

CINLNREG Output Pressure:

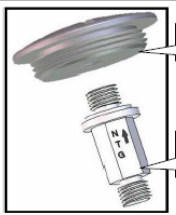
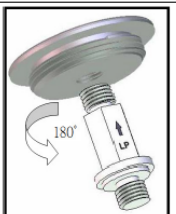
- Propane (LP): 10" WC (water column)
- Natural Gas (NG): 4" WC (water column)

Natural Gas Supply and Connection Guidelines

- **Key Characteristics of Natural Gas:**
 - Natural gas is flammable, lighter than air, and can dissipate quickly in open spaces.
 - Natural gas is odorless in its natural state; an odorant is added for safety to help detect leaks.
- **Safety Precautions:**
 - Ensure all natural gas connections are correctly installed and regularly inspected for leaks or damage.
 - Never store or use natural gas appliances in confined or poorly ventilated spaces.
 - Always follow local codes and regulations when handling or installing natural gas systems.

Professional Installation

Important: All natural gas connections must be performed by a licensed contractor or a representative from the local gas company.

Natural Gas Regulator Guidelines

- **Model:** GR120
- **Gas Pressure:** 4" (101.6mm)
- **Maximum Working Pressure:** 1/2 Psig
- **Leak Testing:** Always leak-test the regulator before use. Do not operate the grill without performing this test.
- The regulator should be installed directly to the back of the grill or after the shutoff valve.



Natural Gas Supply and Connection Instructions

1. Prepare the Grill:
 - Ensure all burner valves are in the "OFF" position.
2. Install Regulator and Shut-Off Valve:
 - All NG grills require a regulator and shut-off valve on the supply line.
3. Seal Pipe Threads:
 - Use gas-rated, outdoor-rated thread sealant on all pipe threads. Flare ends do not require or use sealant.
4. Attach Regulator:
 - Your Coyote NG grill includes a 1/2" regulator:
 - The regulator has a directional arrow showing the correct gas flow direction (arrow pointing toward the grill).
 - Attach a connection hose (not included) to the "in" side of the regulator, which is 1/2" MIP.
5. Connect the Hose:
 - Use **1/2" stainless steel corrugated hoses** for durability.
 - Ensure the hose length and capacity are suitable for your application.
 - Connect the other end of the hose to the shut-off valve.
6. Leak Testing:
 - Test all connections with the soap and water solution as described above.

Liability Disclaimer

Coyote is not responsible for the selection, performance, or workmanship of contractors or installers who connect the natural gas supply to the grill.

Gas Conversion Guidelines

Gas Conversions: Natural Gas (NG) and Propane (LP)

Coyote grills are designed to be convertible between liquid propane (LP) and natural gas (NG). To ensure proper and safe conversion:

1. **Use the Correct Conversion Kit:**
 - Obtain the appropriate Coyote conversion kit, available through your dealer or Coyote's Customer Support Department.
 - Using non-Coyote kits or orifices will void your grill's warranty.
2. **Hire a Professional:**
 - Gas appliance conversions should be performed by a **Licensed Plumber** or **Certified Installer**.
3. **Orifice Changes:**
 - Every burner on the grill requires a specific orifice for the desired gas type. Do not forget to replace orifices with **rotisserie** or **sear burners**, if applicable.
4. **Valve Changes:**
 - For burners with safety valves, the valve must be replaced for conversion.

Steps to Convert Main and Sear Burners

Preparation:

1. Pull the grill out of the island or cart.
2. Remove the drip pan and cooking grates.

Disassembly:

3. Unscrew the bolt connecting the manifold pipe to the grill body (located at the back of the grill).
4. Remove the 4 bolts holding the faceplate to the body (front edge where the cooking grates sit).
5. Unscrew the 2 bolts (on each side), attaching the manifold and faceplate assembly to the grill body.
6. Disconnect all wires and flex lines from the valves and igniter assembly, noting their original locations.
7. Slide the entire control panel and valve assembly from the grill body.

Orifice Replacement:

8. Flip the control panel onto its side to access the valves.
9. Using a wrench, remove the orifice at the end of the valve and install the new gas-specific orifice.

10. Main Burner

- Remove the main burner knobs and unscrew the horizontal screws.
- Replace the safety valve controlling the thermocouple. This valve must be entirely changed; the orifice alone cannot be replaced.
- Remove the base bracket holding the center valve to the manifold pipe and remove the valve.
- Install the new safety valve for the correct gas type, reversing the removal steps.

Reassembly:

11. Reassemble the control panel and grill in reverse order.
12. Test all connections with a soapy water solution to ensure no leaks.

Final Testing and Safety

- After reassembling the grill, perform a leak test using a soapy water solution on all connections.
- Check each burner, including the rear and sear, for proper ignition and flame performance.

Following these steps and ensuring proper installation, you can safely convert your Coyote grill between propane and natural gas while maintaining its performance and warranty. For additional assistance, contact Coyote Customer Support.

Leak Testing Instructions

Leak testing is mandatory before using the grill.

1. Do not smoke or use open flames during the test.
2. Mix a solution of equal parts mild detergent or liquid soap and water.
3. Turn all grill control knobs to **OFF**.
4. Open the LP tank valve completely.
 - If you hear a rushing sound, shut the gas off immediately.
5. Apply the soapy solution to all connection points.
 - If bubbles form, there is a leak. Tighten connections and repeat the test.
6. If leaks persist, contact **Coyote Customer Support** at **855-520-1559**.

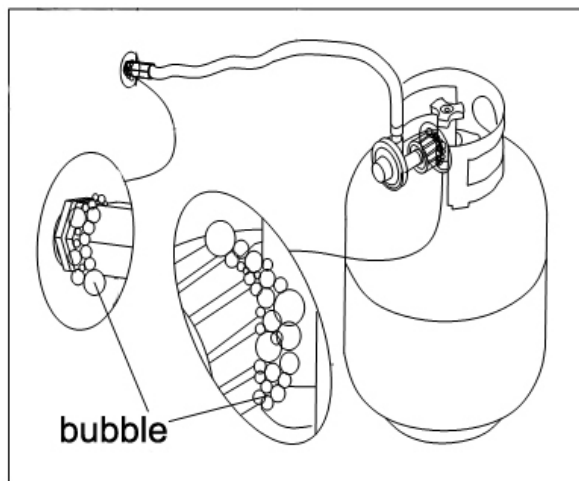

Final Safety Notes

- Never connect the grill to an unregulated gas supply.
- Always ensure the gas supply matches the grill's design type.
- Contact **Coyote Customer Support** at **855-520-1559** with any questions or concerns.

Operating the Grill

⚠ DANGER ⚠

- Failure to open the barbecue lid before igniting the burners or to wait at least 5 minutes for gas to dissipate if the barbecue fails to light can lead to an explosive flare-up, posing a serious risk of severe injury or death.

⚠ WARNING ⚠

- NEVER use the grill if you detect a gas odor.
- NEVER stand with your head, body, or arms over the grill when igniting it.
- ALWAYS inspect the gas hose before use. Replace it immediately if there are signs of excessive wear, abrasion, or cuts. Use only the replacement hose assembly specified by the manufacturer.
- ALWAYS keep the area around the barbecue free from flammable materials such as gasoline, yard debris, or wood.
- ALWAYS check that the airflow through the vent space beneath the grill is unobstructed to ensure safe operation.

GENERAL RULES

⚠ WARNING ⚠ **NEVER leave the grill unattended while cooking!**

- Ensure the grill has been leak-tested and is placed in a location with adequate ventilation and proper clearance.
- Verify that each burner tube is correctly positioned over its corresponding valve orifice.
- Follow the manual's instructions to ignite the grill burners safely.
- Adjust the heat settings to reach your desired cooking temperature.
- After cooking, allow the grill to cool, wipe away splatters or grease, and clean the drip tray.
- NEVER cover the grill while hot, which may pose a fire hazard.

First-Time Use: Burning Off Manufacturing Residue

Before cooking for the first time, operate your grill at the "**HIGH**" setting with the hood closed for no more than **5 minutes**. This will remove any residual odors or debris from the manufacturing and shipping process. After this step, your grill is ready for cooking!

Understanding Your Grill's Valves, Burners

Your grill has **valves** that control gas flow to each burner, and the combo grill has safety valves equipped with **thermocouples** on the main burners, a safety feature to prevent gas flow if the flame goes out. These components, located behind the control knobs, are essential for setting your desired temperature, managing fuel consumption, and ensuring safe operation.

- **Important Reminder:** If a control knob is left on while the burner is unlit, gas can leak through the valve. Always double-check that all knobs are in the "**OFF**" position after using the grill to prevent dangerous gas leaks. Proper use and care of the valves and thermocouples are critical for safe grilling.

Lighting a grill burner with a safety valve equipped with a thermocouple involves a slightly different process than lighting standard burners. The thermocouple is a safety feature attached to the valve, ensuring the gas flow stops if the flame goes out.

Using the Grill's Built-In Ignition System

1. **Select the Burner to Ignite:**
 - Locate the knob corresponding to the burner you wish to light.
 - **Depress and rotate the knob counterclockwise to the "High" position.** As you turn the knob, you will feel resistance as the spring inside the valve builds energy for the igniter.
 - Once you hear a "click," the igniter has sparked to light the burner.
2. **Mind the Knob Rotation Speed:**
 - Turn the knob steadily—not too fast or too slow:
 - **Too fast:** The gas may not reach the burner in time to meet the spark.
 - **Too slow:** Excess gas can build up, potentially causing a large flash when it ignites.
3. **Hold the Knob to Heat the Thermocouple:**
 - Once the burner ignites, **continue pressing the knob in the "High" position for 6-10 seconds.**
 - Pressing the knob allows the thermocouple to heat up and keep the gas valve open.
 - If the flame goes out when you release the knob, the thermocouple may not be sufficiently heated. Repeat the process.
4. **If the Burner Fails to Ignite:**
 - Try lighting the burner again immediately, being cautious of gas buildup.
 - If the burner does not light after three attempts, turn the knob to the **"Off" position**, open the grill canopy, and let the gas clear for **at least 5 minutes** before trying again.
5. **Persistent Ignition Issues:**
 - If the burner still does not ignite or stays lit, the thermocouple may need adjustment or cleaning. Contact **Coyote Customer Support** for further assistance.

Key Safety Notes



Ventilation: Always operate the grill in a well-ventilated area and keep the canopy open during ignition.

- **Gas Buildup:** Be cautious of gas buildup. If ignition fails repeatedly, allow time for the gas to dissipate before retrying.
- **Safety Valve Maintenance:** Keep the valve and thermocouple clean and properly aligned with the burner. If the burner struggles to stay lit, the thermocouple attached to the valve may need to be replaced.
- **Professional Assistance:** For persistent issues, do not attempt repairs yourself. Contact your local technician or **Coyote Customer Support** for help.

Key Safety and Maintenance Notes



1. **Gas Leaks:**
 - Always be vigilant for gas odor (natural gas or propane). Gas leaks are a serious safety concern.
 - If you suspect a leak, immediately shut off the gas supply and inspect the grill.
 - When preparing to light the burners, never stand with your head directly over the grill to prevent possible bodily injury.
2. **Thermocouple Maintenance:**
 - Keep the thermocouples clean and properly aligned with the burners.
3. **Burner Cleaning:**
 - Regularly clean your burners and check the air adjustment screw (Air Venturi) to ensure proper gas flow and combustion.
 - Refer to your manual's **Care and Maintenance** section for detailed cleaning instructions.
4. **Food Safety:**
 - Always practice safe food handling and use a meat thermometer to ensure proper cooking temperatures.

Sear Burner Changeout Instructions

The main burners on CL and SL Series grills can be replaced with sear burners. Follow these steps carefully:

1. **Remove the Existing Burner:**
 - Access the back of the grill and locate the pin securing the burner.
 - Remove the pin and carefully lift the burner out of the grill.
2. **Detach the Thermocouple Bracket:**
 - Locate the thermocouple bracket near the grill burner.
 - Use a Phillips head screwdriver to remove the screw securing the bracket. Set the bracket aside for future use.
3. **Slide Out the Thermocouple:**
 - Gently slide the thermocouple forward out of the bracket.
 - Be cautious not to bend or damage the brass line.
4. **Install the Sear Burner:**
 - Position the replacement burner and secure it using the same pin.
5. **Reattach the Thermocouple:**
 - Slide the thermocouple into the bracket on the sear burner.
 - Clip it securely in place.
6. **Test the Burner:**
 - Ignite the burner following the standard lighting procedure.

Important Safety Note:

- If the burner being replaced fails to ignite, or you detect the smell of the gas, **immediately turn off the gas supply.**
- Double-check the installation for proper alignment.
- Perform a leak test before attempting to ignite the burner again.
- If the tip of the thermocouple gets damaged, it must be replaced.

Removable Heat Zone Dividers

Your grill has **removable heat zone dividers** designed to provide maximum versatility and control over your cooking. These dividers allow you to create separate temperature zones for different cooking methods on the grill.

Using Heat Zone Dividers:

1. Ensure the grill is turned off and completely cool.
2. Open the grill lid and remove the cooking grates.
3. Locate the designated slots or guides for the dividers between the burners.
4. Insert the heat zone dividers into the slots, ensuring they are seated securely.
5. To remove the dividers, allow the grill to cool completely before handling the dividers.
6. Remove the cooking grates to access the dividers.
7. Lift the dividers straight out of their slots for cleaning or to allow heat to flow freely across the grill.

Preparing Food for the Grill **WARNING**

Safe food handling and preparation practices are essential to prevent foodborne illnesses.

Always follow these guidelines:

1. **Cooking and Preparation:**
 - Cook foods thoroughly to kill bacteria, especially if previously thawed or exposed to warm conditions.
 - Keep uncooked foods refrigerated until ready to grill.
 - Marinate meat in the refrigerator and discard excess marinade—**never reuse it.**
2. **Preventing Cross-Contamination:**
 - Use **separate plates and utensils** for raw and cooked food.
 - Never place cooked food on a plate that previously held raw food.
 - Wash all plates, utensils, and surfaces that have encountered raw food before reusing.
3. **Food Hygiene:**
 - Wash vegetables, seafood, and poultry thoroughly before cooking.
 - Store leftovers in the refrigerator within **2 hours** of cooking.

Care and Maintenance

Comprehensive Grill Maintenance and Care Instructions

Drip Tray Maintenance

- **Cleaning:** The drip tray below the grill should be cleaned periodically to prevent debris and grease buildup.
- **Cooling:** Allow the drip tray to cool completely before cleaning it.
- **Weather Precautions:** Do not leave the grill uncovered during inclement weather. Rainwater can be collected inside the grill, cart, or drip tray.
- If the drip tray is left uncleaned and uncovered, water mixed with grease may overflow, damaging the grill cart.
- **Recommendation:** Clean and store the drip tray after every use.

Cooking Grates

- **Post-Cooking Cleaning:** Use a barbecue mitt and a damp cloth immediately after cooking while the grates are still warm. Exercise caution, as the grates will be very hot.
- **For Cooled Grates, Remove the** cooled grates from the grill and clean them with a mild detergent for easier debris removal.

Heat Control Grids

- **Periodic Cleaning:** Occasionally clean the heat control grids with warm, soapy water.
- Use a wire brush to remove stubborn, burned-on residue after the grids have cooled.
- Ensure grids are thoroughly dried before reinstalling them into the grill.

Burner Care

Main Burners:

1. Ensure gas control knobs are in the "**OFF**" position and the fuel source is disconnected.
2. Allow burners to cool completely before cleaning.
3. Remove the burners by unscrewing the nuts, holding them in place, and then carefully lifting them away from the gas valve orifice.
4. Brush the outer surfaces with a wire brush and clean clogged ports with a stiff wire or paper clip.
5. Inspect for damage (cracks or holes). Replace it if necessary.
6. Reinstall the burners, ensuring the gas valve orifices align with the burner tubes. Check the spark electrode position.

Sear Burners:

1. Remove large food debris from the burner surface.
2. Turn the burner to **high heat** and allow it to burn off excess grease. Monitor for flare-ups.
3. After burning off debris, the burner is ready for use.
4. **Tip:** Run the burner a few minutes after cooking to simplify cleanup and avoid reheating the grill later.

Stainless Steel Care and Maintenance

- **Cleaning Process:**
 1. Allow the grill to cool completely before cleaning.
 2. Wash off dirt and debris with warm water. For tough spots, use a third-party degreaser.
 3. Rinse and dry with a clean towel to prevent water spots or discoloration.
 4. Apply a third-party stainless-steel polish to protect the exterior (do not use it on cooking grates or heat control grids). Follow the Polish manufacturer's instructions.
 5. If discoloration or rust occurs, clean it as above and use polish to restore the surface.
- **Environmental Factors to Consider:**
 - Avoid exposure to mortar, pool chemicals, hard water, salt air, dust, rust particles, and organic matter. If not promptly cleaned, these can cause surface discoloration or corrosion.
 - Do not leave cleaning solutions or sprays containing salt, acid, or alkaline substances on the grill.

Annual Grill Housing Cleaning

1. Allow the grill to cool completely and disconnect the gas supply.
2. Remove cooking grids, heat control grids, and burners for cleaning.
3. Wash the warming rack with mild detergent and warm water.
4. Cover gas valve orifices with aluminum foil to prevent debris entry.
5. Brush the grill's interior with a stiff wire brush and wash with soapy water.
6. Remove the foil, check orifices for obstructions, and test the electrode spark.
7. Reinstall all components and reconnect the gas supply. Check burner flames for proper operation.

Important: Do not line the grill bottom with foil, sand, or absorbent substances, as these can block grease flow and cause a grease fire.

Maintenance Guidelines

1. Keep the grill area clear of combustible materials and flammable substances.
2. Ensure proper airflow for combustion and ventilation.
3. Check the burner flames regularly—they should be blue and stable, with no yellow tips or excessive noise. Address issues promptly.
4. Clean the appliance and special surfaces with recommended cleaning agents.
5. Inspect and clean burners for insect nests or blockages to prevent fires beneath the grill.

Avoiding Rust and Scratches

- **Rust Prevention:** Use a **Coyote Grill cover** for protection against contaminants.
- Keep the grill covered during masonry work or near splashing pool chemicals.
- **Scratch Removal:** Use a third-party scratch repair kit to resurface stainless steel, following product instructions carefully.

By following these detailed maintenance and care guidelines, your grill will remain in excellent condition.

Troubleshooting your Grill

General Troubleshooting Guide

Inspect your burners at least once a year or immediately if any of the following conditions occur:

- You smell gas.
- Burner flames appear primarily yellow.
- The grill does not reach the proper cooking temperature.
- Burners produce a snapping or popping noise.
- The grill heats unevenly.

When to Check for Spiders/Insects

Spiders and insects can obstruct the burner venturi, causing operational issues. Inspect the burners once a year or immediately after experiencing any of the following:

1. The smell of gas combined with yellow flames.
2. The grill does not heat to the expected temperature.
3. The grill heats unevenly.
4. Burners make popping noises.

Troubleshooting Guide

If the grill is not functioning correctly, use the information below for guidance.

Safety First: If you cannot resolve the issue, contact **Coyote Customer Support** at **855-520-1559**.

The grill will not ignite.

- Ensure the **gas supply** is turned on.
- If using LP gas, verify there is fuel in the tank. Check the gas level.
- Confirm that at least one burner is turned on, allowing up to **5 seconds of gas flow** to ignite.
- Check if the igniter is working. You should hear a snapping sound.
- Check for a spark at the electrodes if there is a snapping sound. (Remove cooking grates and heat control grids to inspect.)
- Ensure the electrode gap is **1/8" to 1/4"** between the electrode and contact point.
- Inspect for loose wire connections to the igniter or electrodes.
- Clear any debris blocking the electrodes.
- If the igniter still does not work, try lighting the grill manually with a lighter.

Flare-ups

- Check for excess grease or food debris on heat control grids and cooking grates.
- Ensure the drip tray is clean (do not line it with aluminum foil).
- Avoid placing the grill directly in the path of wind.
- **Note: Some flare-ups are normal when cooking greasy foods.**

Yellow flames

- Check burner air inlets for obstructions, such as debris or insect nests.
- Ensure the grill is not in an overly windy location.

If the flame blows out on a low setting or uneven heat

- Inspect the venturi tubes for spider webs or insect nests and clean them thoroughly.
- Preheat the grill on high for **5 minutes** before cooking.
- Ensure the venturi tubes are correctly aligned over the orifices.
- Relocate the grill to a less windy area, especially in cold or windy weather.
- Check for sufficient fuel. Confirm that the cylinder valve is open and that the cylinder contains fuel.



Low heat on the "HIGH" setting

- Inspect the fuel hose for kinks or bends.
- Clear dust or debris from the grill area.
- Verify gas supply and pressure.
- Clean the burner and orifice if the issue affects only one burner.

The grill is too hot.

- Excess grease buildup may cause grease fires.
- Replace damaged or faulty regulators with factory-authorized parts.
- Lower the cooking temperature setting.

Flame behind the control panel or knobs.

- **IMMEDIATELY shut off the cylinder valve and let the grill cool.**
- Inspect venturi tubes for obstructions and clean them.
- Tighten loose connections with a wrench and replace any damaged parts. Perform a leak test before reusing the grill.
- Realign the venturi tubes over the orifices.
- If you cannot find the issue, contact Customer Support.

Fire at any connection

- **IMMEDIATELY shut off the cylinder valve and let the grill cool.**
- Tighten connections with a wrench and replace damaged parts. Perform a leak test before using the grill.
- If unresolved, contact Customer Support.

Important Notes

- For safety, always inspect burners for blockages or misalignment after extended periods of non-use.
- Always err on the side of caution when dealing with potential gas leaks or malfunctioning equipment.
- **Contact Customer Support:** Call 855-520-1559 for expert assistance with unresolved issues.



Controlling Flare-Ups

Flare-ups are a natural part of grilling meat and contribute to the unique flavor of gas grilling. However, excessive flare-ups caused by grease buildup can overcook food and create safety risks.

Follow these tips to minimize and control flare-ups:

1. **Minimizing Flare-Ups:**
 - Trim excess fat from meat before cooking.
 - Cook fatty meats like chicken or pork on **low heat** or indirectly.
 - Ensure the grill is on **level ground**, allowing grease to drain properly through the evacuation hole.
2. **Managing Flare-Ups:**
 - If a grease fire occurs, **close the hood** and turn off the burners. Wait for the grease to burn out.
 - Use caution when reopening the hood, as flare-ups may occur suddenly.

Never pour water on flames, which can cause splattering and severe burns.

Parts Listing

C3CO50 Exploded Parts View

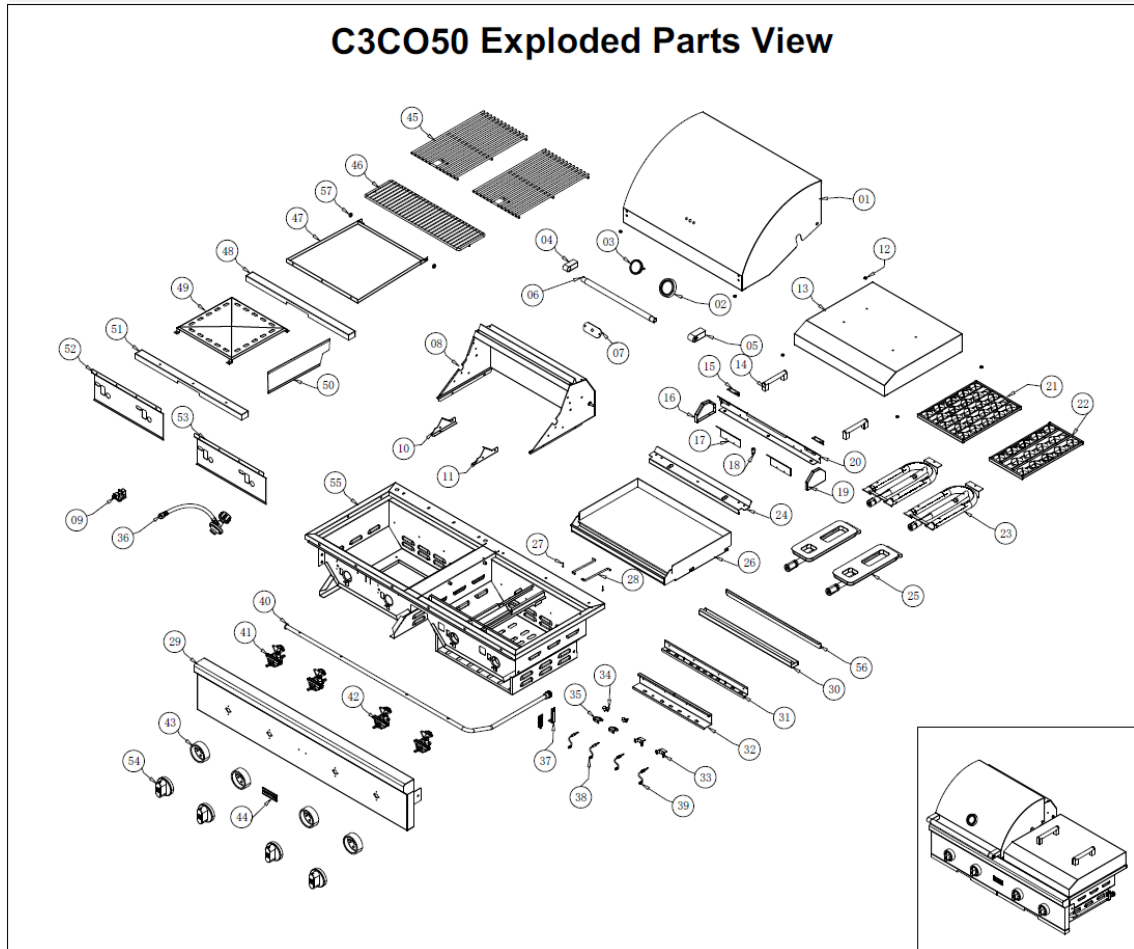

No.	Part Type	Part Number	Qty	No.	Part Type	Part Number	Qty
1	Hood C3 50	C3CO0005	1	31	Burner Support Plate Gas	C3CO0008	1
2	Thermometer Base	C1000044	1	32	Burner Support Plate Flattop	C3CO0009	1
3	Thermometer	C1000022	1	33	Thermocouple support sheets C3 Griddle	C3000023	2
4	Handle End Cap Left C3	C3000008	1	34	Thermocouple support sheets C3 Grill	C3000022	2
5	Handle End Cap Right C3	C3000007	1	35	Thermocouple support plates C3	C3000021	2
6	Hood Handle C3 50	C3CO0006	1	36	LP Regulator	C0000030	1
7	Thermometer Cover C3	C3000014	1	37	Gas Pipe Clamp	C1000045	1
8	Lower Hood Gas C3 CO50	C3CO0007	1	38	Thermocouple 350mm C3	C3000350	2
9	NG Regulator	C1000038	1	39	Thermocouple 250mm C3	C3000250	2
10	Warming Rack Bracket Left C3	C300025L	1	40	Gas Pipe C3 CO50 LP	C3CO040L	1
11	Warming Rack Bracket Right C3	C300025R	1	41	Gas Pipe C3 CO50 NG	C3CO040N	1
12	Rubber Stopper on Hood	C0000032	6	42	Main Safety Valve Grill C3 LP	C3LP0012	2
13	Lid C3 CO50	C3CO5018	1	43	Main Safety Valve Grill C3 NG	C3NG0013	2
14	Lid Handle C3	C3000013	2	44	Main Safety Valve Flat Top C3 LP	C3LP0050	2
15	Vent Hinge	C3CO0015	2	45	Main Safety Valve Flat Top C3 NG	C3NG0051	2
16	Vent Side Left	C3CO0016	1	46	Knob Base C3	C3000012	4
17	Vent Mirror	C3CO0017	2	47	Logo Badge	CH500019	1
18	Vent Knob	C3CO0018	1	48	Grate 13 Bar	C1H50008	3
19	Vent Side Right	C3CO0019	1	49	Warming Rack	C1H50007	1
20	Griddle Vent	C3CO0020	1	50	Drip Tray C3 CO50	C3CO0047	1
21	Heat Control Grid C3 CO Large	C3CO0021	1	51	Drip Tray Front Bar Grill C3 CO50	C3CO0012	1
22	Heat Control Grid C3 CO Small	C3CO0022	1	52	Firebox Bottom Cover C3	C3CO0014	1
23	U Burner	C3CO0023	2	53	Heat Zone Divider C3	C3000010	1
24	Upper hoarding	C3CO0024	1	54	Drip Tray Front Bar Griddle C3 CO50	C3CO0051	1
25	Infinity Burner	C3CSL001	2	55	Heat Resistance Barrier C3 CO Gas	C3CO0052	1
26	Griddle	C3CO0026	1	56	Heat Resistance Barrier C3 CO Griddle	C3CO5022	1
27	R Type Cotter Pin	C3CO0027	1	57	Knob C3	C3000011	4
28	Griddle Support Rod	C3CO0028	2		Firebox C3 CO50	C3CO5055	1
29	Control Panel C3 CO50	C3CO0001	1		Baffle plate C3 CO50	C3CO5056	1
30	Grease Tray	C3CO0010	1		Drip Tray Wheel	C0000057	2